

## Development of Health Kiosk Prototype for Blood Pressure and Fat Mass Measurement

Umiatin Umiatin<sup>1\*</sup>, Pinkan Amanda Putri<sup>1</sup>, Ahmad Zatnika Purwalaksana<sup>1</sup>, Firas Al Farizy<sup>2</sup>, Muhammad Nurdin<sup>2</sup>, Bedy Purnama<sup>3</sup>, Rista Putri Nur Ifa<sup>4</sup>, Muhammad Abidin<sup>4</sup>

<sup>1</sup>Department of Physics, Faculty of Mathematics and Natural Sciences, Universitas Negeri Jakarta, Jakarta, 13220, Indonesia.

<sup>2</sup>Department of Electronic Engineering, Faculty of Engineering, Universitas Negeri Jakarta, Jakarta, 13220, Indonesia.

<sup>3</sup>Center of Excellence Artificial Intelligence for Learning and Optimization, Universitas Telkom, Bandung, 40257, Indonesia.

<sup>4</sup>Frenmed Inovasi Bangsa, Jakarta, 16413, Indonesia.

(Received August 11, 2025; revised September 27, 2025; accepted October 07, 2025; published online October 10, 2025)

Health development in Indonesia faces a double burden of disease, namely infectious and non-communicable diseases (NCDs), with cardiovascular diseases (CVDs) accounting for nearly half of NCD-related deaths. Major CVD risk factors are hypertension and obesity, which can be controlled through routine monitoring of blood pressure and body mass index (BMI). This study aims to develop a health kiosk prototype integrating a sphygmomanometer and BMI-fat analyzer. The research consists of three stages: characterization of sensors for blood pressure and body fat measurement, comparison of proximity sensors, and prototype testing. The MPX5050GP pressure sensor achieved an  $R^2$  of 1 with a sensitivity of 0.012 volts. Proximity sensor characterization showed  $R^2$  values of 0.9996 (HC-SR04) and 0.9997 (JSN-SR04T), with sensitivities of 0.9943 cm and 0.9831 cm, respectively. The load cell reached an  $R^2$  of 1 with a sensitivity of 1.0056 kg, while the AD5933 impedance showed  $R^2 = 1$  and a sensitivity of 0.9999  $\Omega$ . Prototype trials with ten samples indicated that blood pressure, BMI, and fat mass measurements were feasible but not yet optimal, with errors in height measurement and limitations in the blood pressure algorithm. Despite these challenges, the successful integration of the sphygmomanometer and BMI-fat analyzer was achieved.

**Keywords:** *Arduino, bioimpedance, blood pressure, fat mass, pressure sensor.*



This is an open access article under the [CC BY-NC](https://creativecommons.org/licenses/by-nc/4.0/) license.

Copyright © 2025 by Author. Published by Physical Society of Indonesia

### 1. INTRODUCTION

In recent decades, Indonesia has faced a health challenge often described as the triple burden of diseases: infectious diseases (CD), new infectious diseases, and non-communicable diseases (NCDs). At the beginning of the 21st century, however, changes in lifestyle, environment, and technology have shifted the epidemiological profile from infectious diseases to NCDs. Globally, NCDs cause 41 million of the 51 million annual deaths (71%), consisting of cardiovascular disease (44%), cancer (9%), chronic respiratory disease (9%), and diabetes (4%). Indonesia ranks fifth worldwide in cardiovascular disease-related mortality, after China, India, Russia, and the United States (Arifin et al., 2022; Budreviciute et al., 2020; Kristanti et al., 2021; Roth et al., 2020).

Cardiovascular disease is a condition related to the heart and blood vessels. Risk factors for cardiovascular disease are classified into modifiable and non-modifiable risk factors. Modifiable risk

\*Contact Author: [umiatin@unj.ac.id](mailto:umiatin@unj.ac.id)

factors include blood pressure, obesity, physical inactivity, smoking, and elevated blood cholesterol levels (Budreviciute et al., 2020).

According to the American Heart Association, the main causes of cardiovascular disease include hypertension and obesity. Based on the 2018 Riskesdas, the prevalence of hypertension in Indonesia increased from 25.8% to 34.1%, while obesity rose from 14.8% to 21.8%. Hypertension is defined as systolic blood pressure  $\geq 140$  mmHg and/or diastolic pressure  $\geq 90$  mmHg, while obesity is defined as a body mass index (BMI)  $\geq 27$  (Roth et al., 2020; Wang et al., 2021). Obesity is considered a global 21st-century epidemic and is strongly related to cardiovascular disease (Gaździńska et al., 2023), with the prevalence of obesity-related diseases increasing over the past three decades (Carter et al., 2023).

The increasing evidence of cardiovascular disease places a significant burden on the national healthcare system and poses a risk to economic growth. Therefore, the Ministry of Health of the Republic of Indonesia has implemented various strategic efforts for prevention and early detection, including through health promotion and preventive programs at Posbindu (community-based integrated health post). Posbindu plays a role in early detection among communities at high risk for cardiovascular disease by regularly monitoring blood pressure, body mass index (BMI), and blood cholesterol levels (Alzahrani et al., 2024; Nugraheni et al., 2022; Prabandari et al., 2023; Wirawati & Widyaningsih, 2022).

Besides blood pressure, cardiovascular disease is also closely associated with obesity. Obesity is generally assessed using anthropometric indicators such as BMI. However, BMI has limitations, as it cannot distinguish between weight gained from fat mass and that from muscle mass (Gaździńska et al., 2023). Therefore, body fat composition measurement is required (Sheibani et al., 2020). Typically, dual-energy X-ray absorptiometry (DXA) is used for body fat composition measurement due to its high accuracy, but it is expensive and only available in type A hospitals. Another method that can be used is Bioelectrical Impedance Analysis (BIA), which has advantages such as being non-invasive, radiation-free, portable, fast, and efficient (Luciani et al., 2019; Wiranata & Inayah, 2020).

Currently, Posbindu routinely measures blood pressure and BMI as part of preventive efforts against CVD. However, body fat composition measurements have not yet been performed at Posbindu. Despite its strategic role, Posbindu faces various challenges, including the need to strengthen the knowledge and skills of community health volunteers and to improve infrastructure and equipment. Limited availability of tools remains a barrier to program implementation (Yunia & Wahyono, 2021). At present, the tools used at Posbindu include scales, height measuring tools, waist circumference measuring tools, sphygmomanometers (blood pressure measurement), cholesterol test kits, and blood glucose test kits. However, body composition analyzers are still unavailable (Mahdur & Sulistiadi, 2020). Another limitation is that Posbindu is still managed manually, particularly in data management, which increases the administrative burden and reduces service efficiency (Yuliana & Sancoko, 2023).

Regular monitoring of hypertension and obesity risk factors is necessary in the community, including at Posbindu, as a part of promotional and preventive strategies for controlling non-communicable diseases (NCDs). NCD risk factors can be monitored through regular checks of blood pressure, body weight, and BMI. Regarding blood pressure measurement, Umiatin et al. have developed a fully automatic sphygmomanometer prototype using the MPX5050GP sensor and Arduino microcontroller (Aldaciptarisa et al., 2024; Umiatin et al., 2024). Previous studies have also developed integrated body weight and height measuring tools with an error rate of less than 5% (Umiatin et al., 2022). This study aims to integrate a sphygmomanometer and BMI-Fat Analyzer into a prototype of a self-service health kiosk that can be used for monitoring NCD risk factors.

## 2. METHOD

### 2.1 Block Diagram of the System

A block diagram of the system is presented in Figure 1. The developed Health Kiosk consists of a BMI-Fat Analyzer for measuring body weight, height, Body Mass Index (BMI), Fat Mass, and Fat-Free Mass, as well as a sphygmomanometer for blood pressure measurement. The BMI-Fat Analyzer is designed using AD5933 for impedance measurement, HC-SR04 ultrasonic sensor for height measurement, and a single-point load cell for weight measurement. The sphygmomanometer is

developed using the MPX5050GP pressure sensor, DC motor, and solenoid valve. The prototype uses Arduino Mega 2560 as the microcontroller. A Nextion LCD is used for the display, and a thermal printer is included to print the test results.

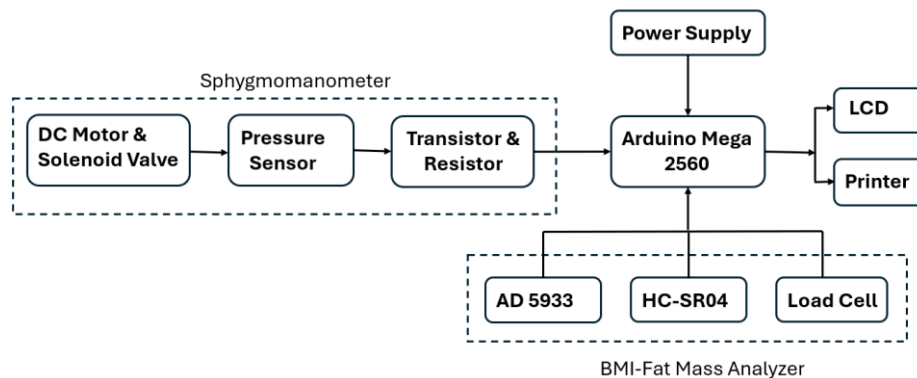


Figure 1 System Block Diagram.

### 2.2 Electronic Circuit Design

The electrical circuit configuration of the health kiosk prototype is shown in Figure 2.

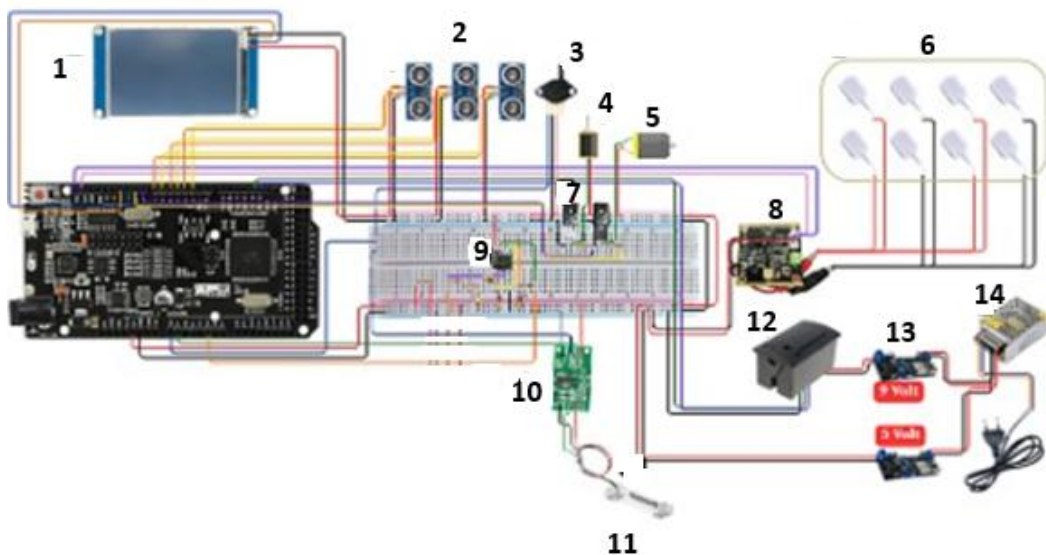


Figure 2 Complete system design comprising components: 1. Nextion; 2. HC-SR04; 3. MPX5050GP; 4. DC Motor; 5. Solenoid Valve; 6. Electrode Pad; 7. BD139 Transistor and Resistor; 8. AD5933; 9. LM358 IC; 10. HX711 Module; 11. Single Point Load Cell; 11. Thermal Printer; 13. Step Down Converter; 14. Power Supply.

### 2.3 Data Collection Stage

This research consists of three main stages: 1) Sensor characterization, including the pressure sensor, ultrasonic sensor, and AD5933, 2) Development of electronic circuits and measurement algorithms for blood pressure and body composition (weight, height, BMI, fat mass, and fat-free mass). BMI is calculated using equation 1:

$$BMI = \frac{\text{Body mass (kg)}}{\text{Body height (m)}^2} \tag{1}$$

Fat-Free Mass is calculated using equation 2:

$$FFM = 0.36 \left( \frac{H^2}{Z} \right) + 0.162(H) + 0.289(W) - 0.134(age) + 4.83(gender) - 6.83 \tag{2}$$

FFM (Fat-Free Mass), H (Height), W (Weight), Z (Impedance), A (Age), G (Gender). The third stage involves testing the measurements on five individuals, with three repetitions per person.

### 3. RESULTS AND DISCUSSION

#### 3.1 Sensor Characterization

Sensor characterization aims to identify sensor properties such as sensitivity, resolution, accuracy, linearity, and reliability in data acquisition.

##### 3.1.1 MPX5050GP Pressure Sensor Characterization

The MPX5050GP is used for blood pressure measurement. Its output voltage is compared to that of standard aneroid sphygmomanometers (OneMed and GEA) within the range of 0–300 mmHg in 50 mmHg increments, repeated 5 times. The circuit schematic is shown in Figure 3.

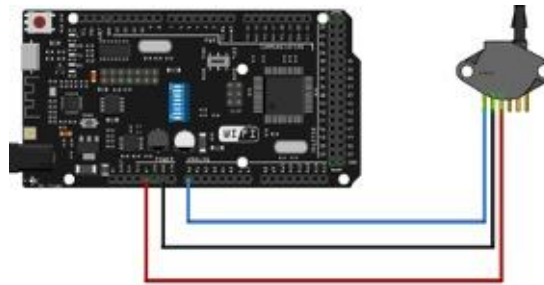


Figure 3 Schematic circuit for MPX5050GP characterization.

The characterization results are shown in Figure 4.

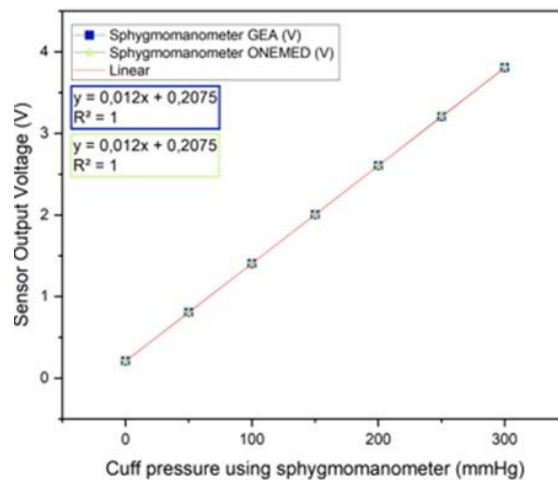


Figure 4 MPX5050GP sensor characterization.

There is a linear relationship between pressure and the sensor's output voltage. This means that the higher the applied pressure, the higher the output voltage. This is because the MPX5050GP sensor operates on the piezoresistive and strain gauge principles, which allow pressure changes to be converted into a proportional voltage signal.

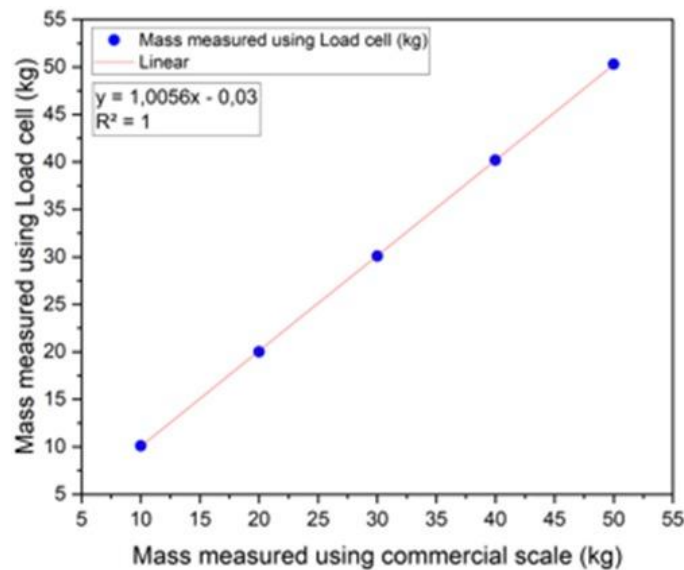
##### 3.1.2 Single Point Load Cell Characterization

The characterization results are shown in Figure 5.



Figure 5 Schematic circuit for load cell characterization.

The characterization results of the Single-Point Load Cell sensor are shown in Figure 6.

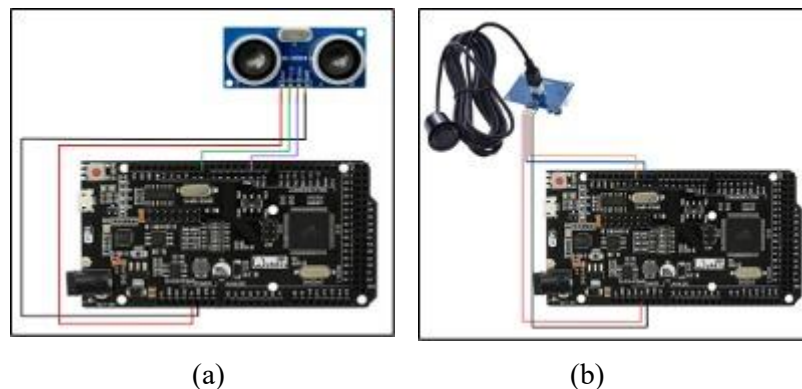


**Figure 6** Load cell characterization.

Based on the graph shown in Figure 6, the coefficient of determination ( $R^2$ ) value of 1 and the sensitivity of 1.0056 indicate that the sensor has very high sensitivity. The very small intercept value of -0.03 indicates that systematic errors in the measurements are very low.

### 3.1.3 Characterization of the HC-SR04 and JSN-SR04T Ultrasonic Sensor

For height measurement, optimization was performed using two types of ultrasonic sensors: the HC-SR04 and the JSN-SR04T. The goal of this optimization was to obtain the most stable and accurate sensors for height measurement. Characterization of the HC-SR04 and JSN-SR04T sensors was performed by comparing the distance measurements obtained from these sensors with those measured using a standard tool (tape measure). This characterization was performed over a range of 150-180 cm in 10 cm increments. Data collection was repeated 10 times to determine sensor sensitivity under the same conditions. The proximity sensor characterization circuit is shown in Figure 7.



**Figure 7** Distance sensor characterization circuit. (a) HC-SR04 sensor, (b) JSN-SR04T sensor.

The characterization results of the JSN-SR04T and HC-SR04 sensors are shown in Figure 8. The JSN-SR04T sensor has a minimum range of 20 cm and a range angle of  $75^\circ$ , causing the sensor to frequently detect nearby objects. The HC-SR04 sensor has a minimum range of 2 cm and a range angle of  $15^\circ$ , making it more stable and optimal for height measurements. Furthermore, to obtain more accurate and stable distance readings, optimization was performed using three HC-SR04 sensors with a sensor spacing configuration of 10 cm and 3 cm, as shown in Figure 9.

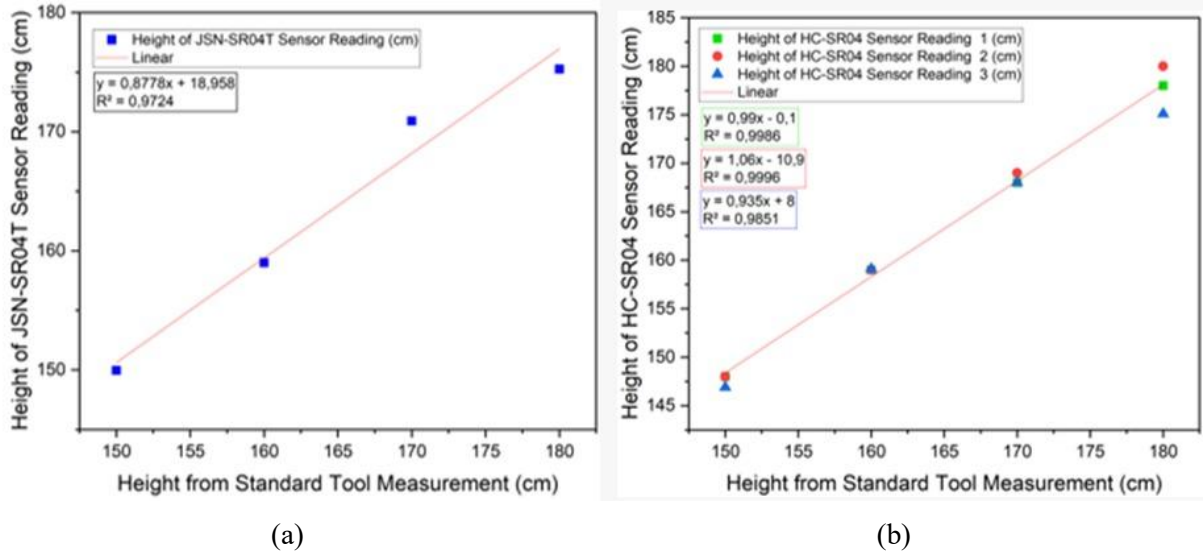


Figure 8. Ultrasonic sensor characterization graph (a) JSN-SR04T, (b) HC-SR04.

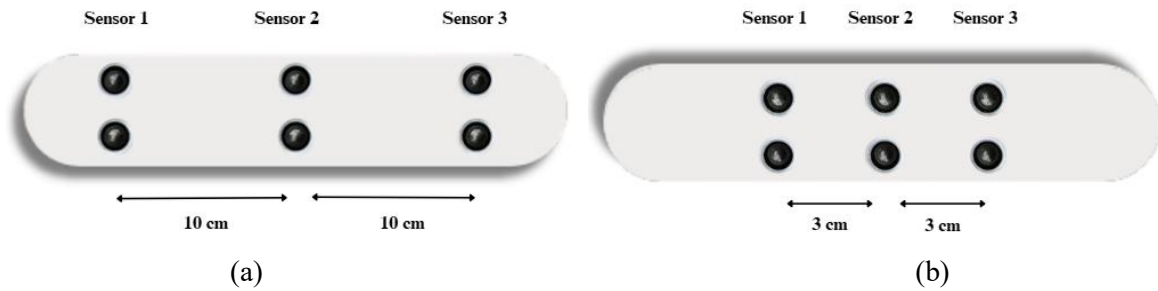


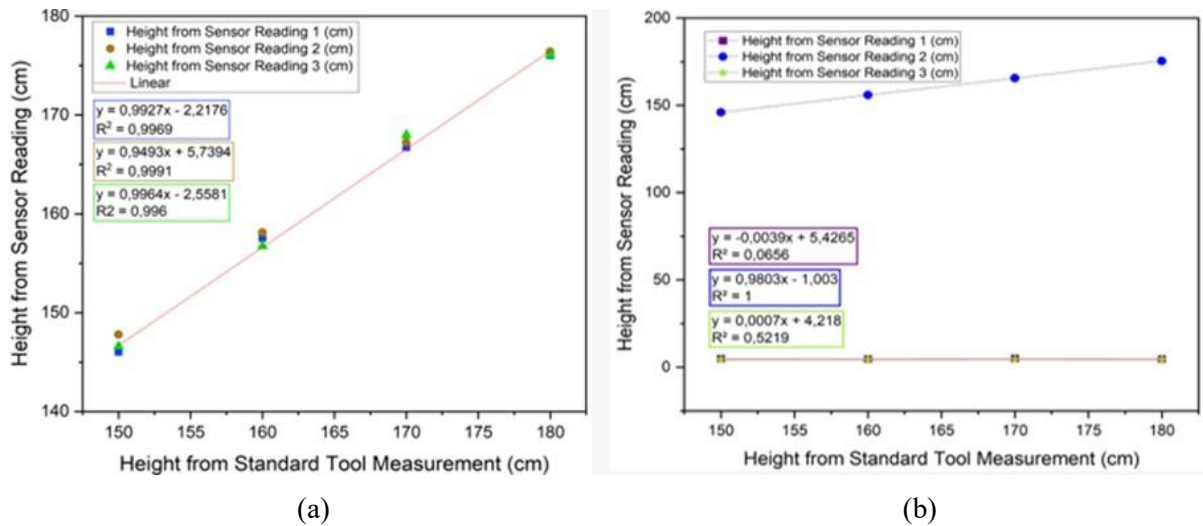
Figure 9. Illustration of Three HC-SR04 Sensors (a) Distance Between Each Sensor: 10 cm (b) Distance Between Each Sensor: 3 cm.

Characterization was performed using PVC pipes and balls for the height measurement model, as shown in Figure 10.



Figure 10. Model of height measurement

The results of sensor characterization by comparing three HC-SR04 sensors with sensor spacing of 10 cm and 3 cm are shown in the graph shown in Figure 11.

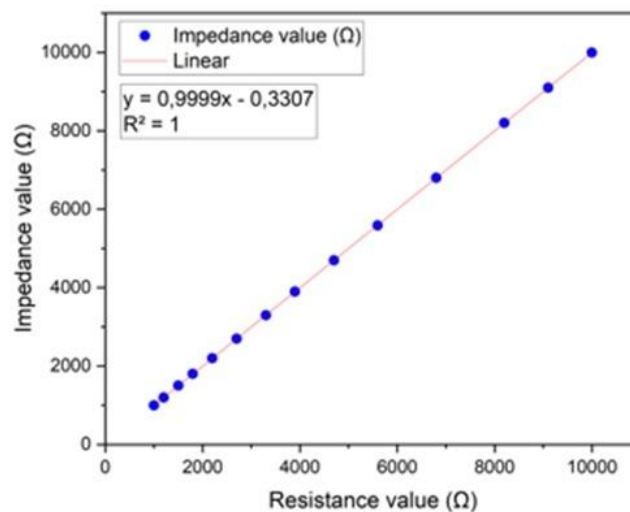


**Figure 11.** Characterization Graph of 3 HC-SR04 Sensors (a) with a Sensor Spacing of 10 cm, (b) with a Sensor Spacing of 3 cm

Figure 11 shows that the HC-SR04 sensor measurements, comparing three ultrasonic sensors with a sensor spacing of 10 cm, yielded more stable results compared to three ultrasonic sensors with a sensor spacing of 3 cm. This is because the HC-SR04 ultrasonic sensor has a detection angle of 15°, resulting in the reflection of the emitted waves colliding between the sensors. Therefore, the characterization experiment comparing three ultrasonic sensors with a sensor spacing of 3 cm was inaccurate.

### 3.1.4 AD5933 Converter Impedance Characterization

The AD5933 characterization process was carried out by comparing the impedance magnitude output obtained from the AD5933 with a resistance tolerance of 1%. This characterization was performed over the range of 1kΩ–10kΩ at a frequency of 50Hz. Data collection was repeated 10 times to determine sensitivity under the same conditions. This characterization circuit is shown in Figure 12.



**Figure 12.** AD5933 Characterization Graph

Based on the graph above, it can be seen that the impedance value read from the AD5933 sensor has a very strong linear relationship with the resistance value. This is indicated by the coefficient of determination ( $R^2$ ) of 1, indicating a very strong linear relationship between the known resistance value of the resistor and the impedance magnitude read by the AD5933.

### 3.1.5 Display Design

A 7-inch Nextion LCD was used to display the measurement results. The Nextion design was created using the Figma application. The display design consists of several stages: home, user profile (age and gender), measurement type menu, measurement display, and printing the measurement results. Figure 13 below is an example of the Nextion LCD display design.



**Figure 13.** Display on the Nextion (a) for blood pressure measurement, (b) for body composition measurement.

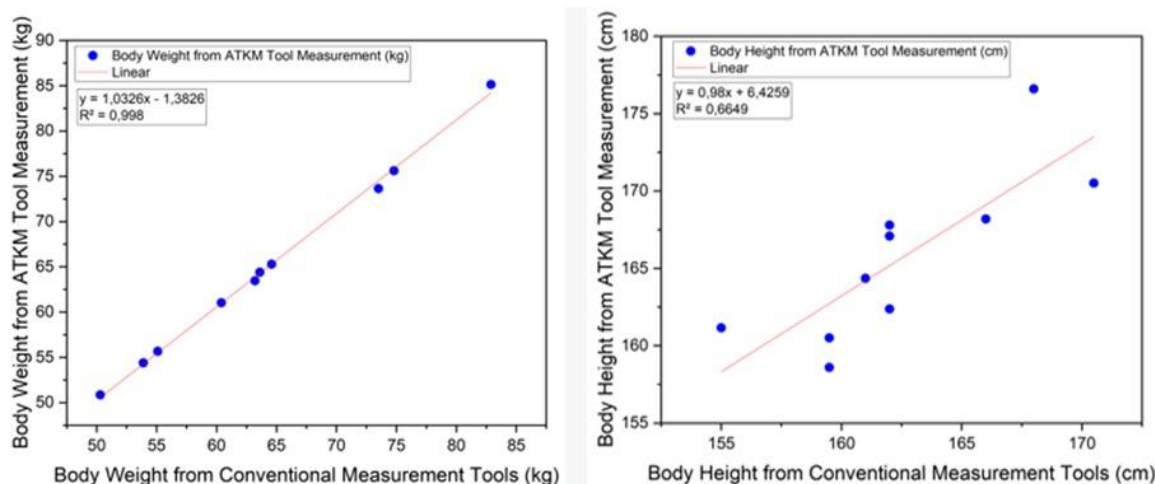
### 3.1.6 Health Kiosk Testing

This testing was conducted on 10 individuals with three repetitions, which were then compared with a conventional standard device, as shown in Figure 14.

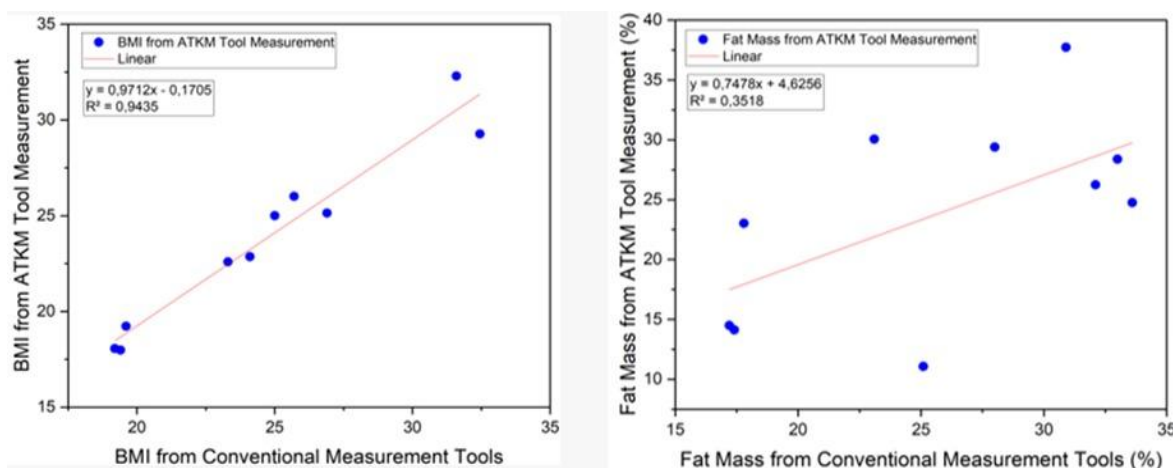


**Figure 14.** Conventional Body Fat Composition Testing (a, b) uses a prototype of a health kiosk, and (c, d) uses a commercial device.

The results of the weight and height measurements from the 10 samples can be seen in Figure 15 and the results of BMI and FFM calculations based on weight and height measurements are shown in Figure 16. The weight measurements were quite accurate and within tolerance limits, with a correlation coefficient ( $R^2$ ) of 0,998. There were inaccuracies in the height measurements. This could be due to the sensor not accurately reading the distance due to several technical factors, such as interference from the surrounding environment, as well as delays or noise in the sensor signal.



**Figure 15.** Comparison of weight and height measurements using the health kiosk and the standard device.



**Figure 16.** Measurement Graph (a) BMI, (b) FFM

Figure 16 shows that the Fat Mass measurement is inaccurate. This is because the Fat Mass calculation includes height, weight, and impedance values. Therefore, if these measurements are not sufficiently accurate, the Fat Mass measurement results will also be inaccurate.

Figure 17 shows that the systolic and diastolic blood pressure measurements are inaccurate. This could be due to mechanical interference or an inadequate processing algorithm.

#### 4. CONCLUSION

The integration of a sphygmomanometer and BMI-Fat Analyzer into a health kiosk prototype has been successfully designed. Sensor characterization results show good performance, including the MPX5050GP sensor with a coefficient of determination ( $R^2$ ) of 1 and a sensitivity of 0.012. BPW34 sensor with an  $R^2$  value of 0.9242 and a sensitivity of -0.0012; and a distance sensor, where the comparison between HC-SR04 and JSN-SR04T produces  $R^2$  values of 0.9996 and 0.9997, respectively, with sensitivities of 0.9943 cm and 0.9831 cm, respectively. Furthermore, the Loadcell sensor shows an

$R^2$  value of 1 with a sensitivity of 1.0056 kg, while the AD5933 sensor for impedance measurement obtains an  $R^2$  value of 1 with a sensitivity of 0.9999  $\Omega$ .

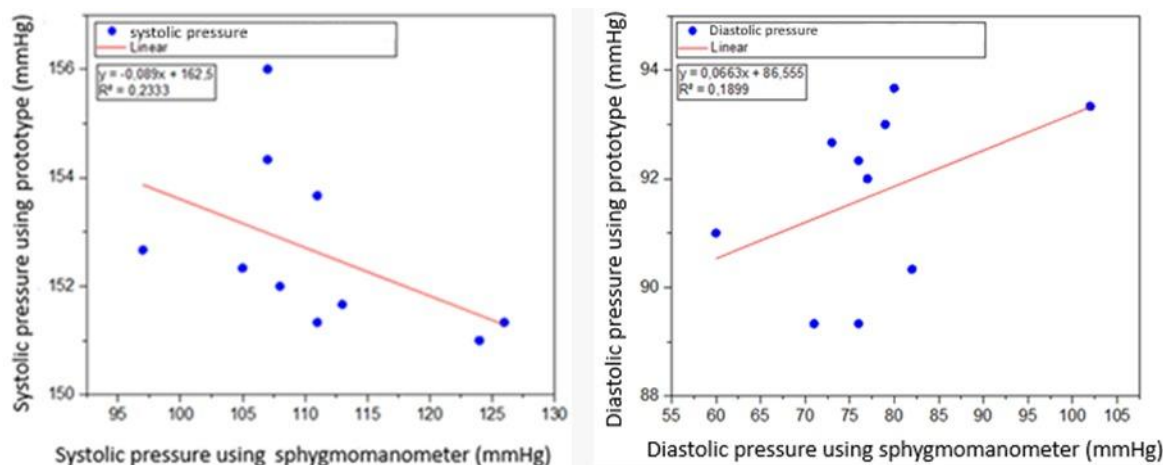


Figure 17. Systolic and diastolic blood pressure measurements

## ACKNOWLEDGEMENT

The research was funded by the Unit of Research and Community Service, Jakarta State University, grant number: 13/PPI/LPPM/III/2024.

## REFERENCE

- Aldaciptarisa, A., Umiatin, U., & Suhendar, H. (2024). Karakterisasi Sensor Mpx5050gp Pada Perancangan Prototipe Sfigmomanometer Digital Full Automatic Berbasis Mikrokontroler. *Prosiding Seminar Nasional Fisika (E-Journal)*, 12, 57–62. <https://doi.org/10.21009/03.1201.FA09>
- Alzahrani, M. S., Albishi, A. H., Alfaifi, A. E., Alzahrani, A. M., Aldoosary, R. I., Alshabeeb, S. Y., Alammari, A. A., Alalrashidi, B. M., Zoqeei, E. M., & Kofiyah, O. A. (2024). Vital signs role and significance in detecting early cardiac events. *International Journal of Community Medicine and Public Health*, 11(1), 419–423. <https://doi.org/10.18203/2394-6040.ijcmph20233847>
- Arifin, H., Chou, K.-R., Ibrahim, K., Fitri, S. U. R., Pradipta, R. O., Rias, Y. A., Sitorus, N., Wiratama, B. S., Setiawan, A., Setyowati, S., Kuswanto, H., Mediarti, D., Rosnani, R., Sulistini, R., & Pahria, T. (2022). Analysis of Modifiable, Non-Modifiable, and Physiological Risk Factors of Non-Communicable Diseases in Indonesia: Evidence from the 2018 Indonesian Basic Health Research. *Journal of Multidisciplinary Healthcare*, 15, 2203–2221. <https://doi.org/10.2147/JMDH.S382191>
- Budreviciute, A., Damiati, S., Sabir, D. K., Onder, K., Schuller-Goetzburg, P., Plakys, G., Katileviciute, A., Khoja, S., & Kodzius, R. (2020). Management and Prevention Strategies for Non-communicable Diseases (NCDs) and Their Risk Factors. *Frontiers in Public Health*, 8, 574111. <https://www.frontiersin.org/journals/public-health/articles/10.3389/fpubh.2020.574111>
- Carter, J. L., Abdullah, N., Bragg, F., Murad, N. A. A., Taylor, H., Fong, C. S., Lacey, B., Sherliker, P., Karpe, F., Mustafa, N., Lewington, S., & Jamal, R. (2023). Body composition and risk factors for cardiovascular disease in global multi-ethnic populations. *International Journal of Obesity*, 47(9), 855–864. <https://doi.org/10.1038/s41366-023-01339-9>
- Gaździńska, A., Gaździński, S., Jagielski, P., & Kler, P. (2023). Body Composition and Cardiovascular Risk: A Study of Polish Military Flying Personnel. *Metabolites*, 13(10), 1102. <https://doi.org/10.3390/metabo13101102>
- Kristanti, D., Rahajeng, E., Sulistiowati, E., Kusumawardani, N., & Dany, F. (2021). Determinants of diabetes comorbidities in Indonesia: A cohort study of non-communicable disease risk factor. *Universa Medicina*, 40(1), 3–13. <https://doi.org/10.18051/UnivMed.2021.v40.3-13>
- Luciani, G., Ramilli, R., Romani, A., Tartagni, M., Traverso, P. A., & Crescentini, M. (2019). A miniaturized low-power vector impedance analyser for accurate multi-parameter measurement. *Measurement*, 144, 388–401. <https://doi.org/10.1016/j.measurement.2019.05.003>

- Mahdur, R. R., & Sulistiadi, W. (2020). Evaluasi Program Pos Pembinaan Terpadu Penyakit Tidak Menular (Posbindu PTM). *Jurnal Ilmiah Kesehatan Masyarakat: Media Komunikasi Komunitas Kesehatan Masyarakat*, 12(1), 43-48. <https://doi.org/10.52022/jikm.v12i1.55>
- Nugraheni, R., Chintya, R., & Cahyono, T. (2022). Evaluasi Pelaksanaan Program Posbindu PTM di Puskesmas Kota Wilayah Utara Kota Kediri. *Jurnal Penelitian Kesehatan "SUARA FORIKES" (Journal of Health Research "Forikes Voice")*, 13(1), 83-87. <httpnus://doi.org/10.33846/sf13115>
- Prabandari, F., Sumarni, & Astuti, D. P. (2023). Faktor-Faktor yang Berpengaruh Terhadap Pemanfaatan Posbindu PTM. *Indonesian Journal of Midwifery (IJM)*, 6(1), 46-54. <https://doi.org/10.35473/ijm.v6i1.2254>
- Roth, G. A., Mensah, G. A., Johnson, C. O., Addolorato, G., Ammirati, E., Baddour, L. M., Barengo, N. C., Beaton, A. Z., Benjamin, E. J., Benziger, C. P., Bonny, A., Brauer, M., Brodmann, M., Cahill, T. J., Carapetis, J., Catapano, A. L., Chugh, S. S., Cooper, L. T., Coresh, J., ... GBD-NHLBI-JACC Global Burden of Cardiovascular Diseases Writing Group. (2020). Global Burden of Cardiovascular Diseases and Risk Factors, 1990-2019: Update from the GBD 2019 Study. *Journal of the American College of Cardiology*, 76(25), 2982–3021. <https://doi.org/10.1016/j.jacc.2020.11.010>
- Sheibani, H., Saberi-Karimian, M., Esmaily, H., Mouhebaty, M., Azarpazhooh, M. R., Divbands, G., Kabirian, M., Ghaffarian, R., Tayefi, M., Ferns, G. A., Safarian, M., & Ghayour-Mobarhan, M. (2020). A comparison of body mass index and body fat percentage for predicting cardiovascular disease risk. *Translational Metabolic Syndrome Research*, 3, 29–34. <https://doi.org/10.1016/j.tmsr.2020.06.001>
- Umiatin, U., Ciptarisa, A., Ifa, R. P. N., & Abidin, M. (2024). Automated Digital Sfigmomanometer Prototype Testing. *Journal of Physics: Conference Series*, 2866(1), 012055. <https://doi.org/10.1088/1742-6596/2866/1/012055>
- Umiatin, U., Indrasari, W., Taryudi, T., & Dendi, A. F. (2022). Development of a Multisensor-Based Non-Contact Anthropometric System for Early Stunting Detection. *Journal of Sensor and Actuator Networks*, 11(4), 69. <https://doi.org/10.3390/jsan11040069>
- Wang, W., Yan, Y., Guo, Z., Hou, H., Garcia, M., Tan, X., Anto, E. O., Mahara, G., Zheng, Y., Li, B., Kang, T., Zhong, Z., Wang, Y., Guo, X., Golubnitschaja, O., & On Behalf of Suboptimal Health Study Consortium and European Association for Predictive, P. and P. M. (2021). All around suboptimal health—A joint position paper of the Suboptimal Health Study Consortium and European Association for Predictive, Preventive and Personalised Medicine. *EPMA Journal*, 12(4), 403–433. <https://doi.org/10.1007/s13167-021-00253-2>
- Wiranata, Y., & Inayah, I. (2020). Perbandingan Penghitungan Massa Tubuh Dengan Menggunakan Metode Indeks Massa Tubuh (IMT) dan Bioelectrical Impedance Analysis (BIA). *Jurnal Manajemen Kesehatan Yayasan RS.Dr. Soetomo*, 6(1), 43–52. <https://doi.org/10.29241/jmk.v6i1.280>
- Wirawati, M. K., & Widyaningsih, T. S. (2022). Optimalisasi Posbindu PTM dalam Pencegahan Penyakit Tidak Menular di Wilayah Kelurahan Tambak Aji Ngaliyan Semarang. *Jurnal Peduli Masyarakat*, 4(1), 109-114. <https://doi.org/10.37287/jpm.v4i1.989>
- Yuliana, A. D., & Sancoko, S. D. (2023). Digitalisasi Pelayanan Pos Pembinaan Terpadu Berbasis Android Untuk Peningkatan Kualitas Kesehatan Masyarakat. *Simpatik: Jurnal Sistem Informasi Dan Informatika*, 3(2), 135-143. <https://doi.org/10.31294/simpatik.v3i2.2858>
- Yunia, G. F., wiranta & Wahyono, B. (2021). Program Pengendalian Penyakit Tidak Menular Berbasis Posbindu di Puskesmas. *Indonesian Journal of Public Health and Nutrition*, 1(3), 590-599. <https://doi.org/10.15294/ijphn.v1i3.51428>